

3i-1510-9B-C

HARDERBACK

Maletas Industriales | Maletines Militares
Estuches de Protección | Cajas Polipropileno
Mochilas Resistentes | Cajas Biométricas



Colores



Especificaciones [Largo x Ancho x Profundo]

Exterior:

[16.25" x 13.00" x 9.80"]
[41.28 x 33.02 x 24.89 cm]

Interior:

[15.00" x 10.50" x 9.00"]
[38.10 x 26.67 x 22.86 cm]

Peso:

[8.33 lb] [3.78 kg]

Certificaciones

MIL-C-4150J / MIL-STD-810F
/ MIL-STD-648C

[Características]

SKB iSeries Moldeado por inyección Mil-Standard
Los estuche impermeables están moldeados de resina de copolímero de polipropileno de muy alta resistencia

- Diseño resistente al agua y al polvo
- Convenientes ruedas de deslizamiento silencioso
- Resistente a los Rayos UVdisolventes, corrosión, hongos (MIL-STD-810F).
- Válvula de equalización de presión ambiente
- Resistente al daño por impacto (MIL-STD-810F).
- Bisagra moldeada para mayor protección

[Configuraciones]

- Sin Foam, Vacío
- Con Foam precortado
- Divisores Think Tank
- Divisores Think Tank y Lid Organizer

[Accesorios]

- 3i-HD80
 - Manijas sobremoldeadas acolchadas.
- 1SKB-PDL-C
 - Candado con cable SKB TSA
- 3i-TSA-3
 - Cada kit incluye 2 pestillos de bloqueo TSA, pasadores de repuesto y 2 llaves.
- 3i-PMCK
 - Panel Mount Clip Kit para los case de la serie 3i
- 3SKB-SLP kit
 - Mide 12" x 7" (30.48 x 17.78 cm)



[3i-HD80]



[1SKB-PDL-C]



[3i-TSA-3]



[3i-PMCK]



[1SKB-PDL]



[3SKB-SLP kit]

[CDMX] 55.1328.0711- 55.8851.8725
[WhatsApp] 55 3851 2609
www.seahorse.mx www.harderback.com

HARDERBACK

3i-1510-9B-C

HARDERBACK

Maletas Industriales | Maletines Militares
 Estuches de Protección | Cajas Polipropileno
 Mochilas Resistentes | Cajas Biometricas

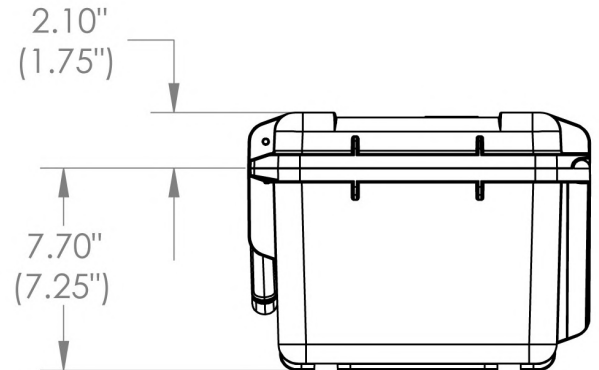
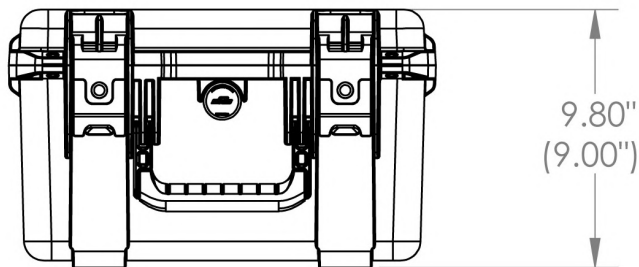
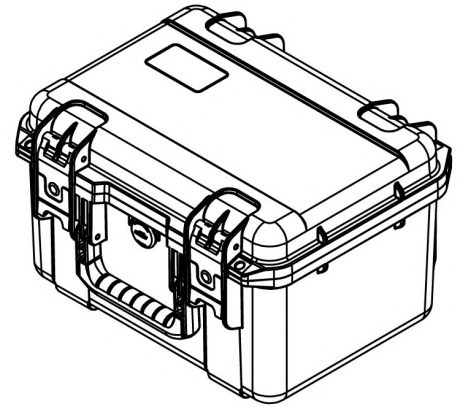
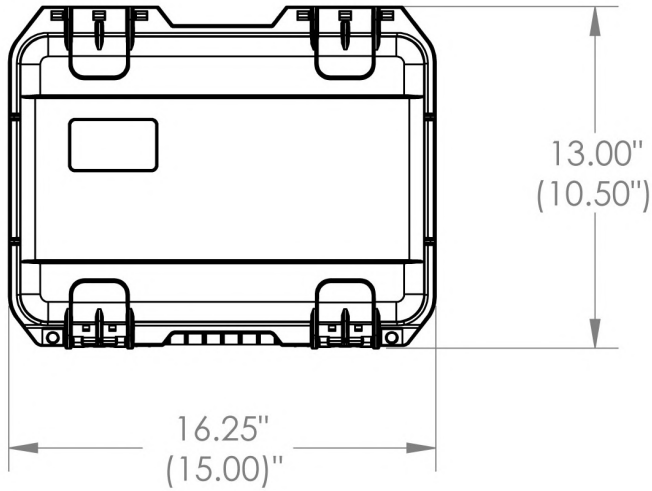

3i-1510-9

NOTE: DIMENSIONS IN (X.XX) ARE ID

This drawing and all information details are the sole property of SKB Corporation, Orange CA. Any unauthorized use will be punished to the full extent of the law.	Case Series:	3i Series	Dimensions (for reference only)				
	Case part#	3i-1510-9	Exterior	Length left to right	Width front to back	Overall height	Base / Lid height
	Weight:	6.15 lbs		Inerior	16.25"	13.00"	9.80"
				15.00"	10.50"	9.00"	7.25"-1.75"